

CASE STUDY

SORTING AND DELIVERING TIMELY INSIGHT

UK INTRA-LOGISTICS COMPANY

How RS Industria is helping a major intra-logistics company improve the performance of a critical asset.



CUSTOMER OVERVIEW

14 million parcels are sent every day in the UK; a figure that has escalated over recent years following the boom in online shopping.

For one major UK-based intra-logistics company, the welcome increase in business also highlighted a performance issue in a key asset at one of its depots.

BENEFITS SUMMARY



ANALYSIS

Collection of real-time data and analysis of asset performance to determine areas of failure.

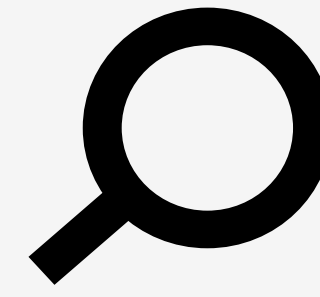

VISIBILITY

Discovered root cause of excessive wear on gearboxes and conveyor bearings, using insight to inform future maintenance strategy.

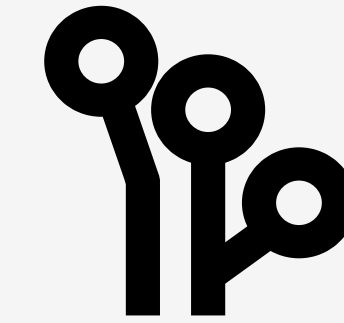

REAL-TIME DATA

Continuous and improved monitoring implemented to mitigate further issues, with data available 24/7.

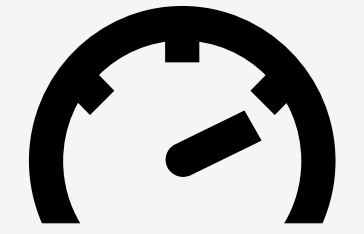

OPTIMISATION

Insight enables effective asset management, contributing to an extension of equipment and component lifespan and a reduction in downtime.

THE PROBLEM

The customer's parcel sorting machine is a complex unit used to grade parcels by weight and volume. Custom-designed for the job, the machine has a total of 11 conveyors, consisting of five sorting lanes. Each lane has two conveyor runs to sort parcels before they are then loaded onto a large carousel.

Despite being relatively new, the bearings in several of the machine's gearboxes and conveyor rollers were showing excessive wear and required replacement well before the end of their expected service life. In addition, oil analysis results showed contamination, which meant the gearbox oil needed to be changed far more frequently than anticipated.

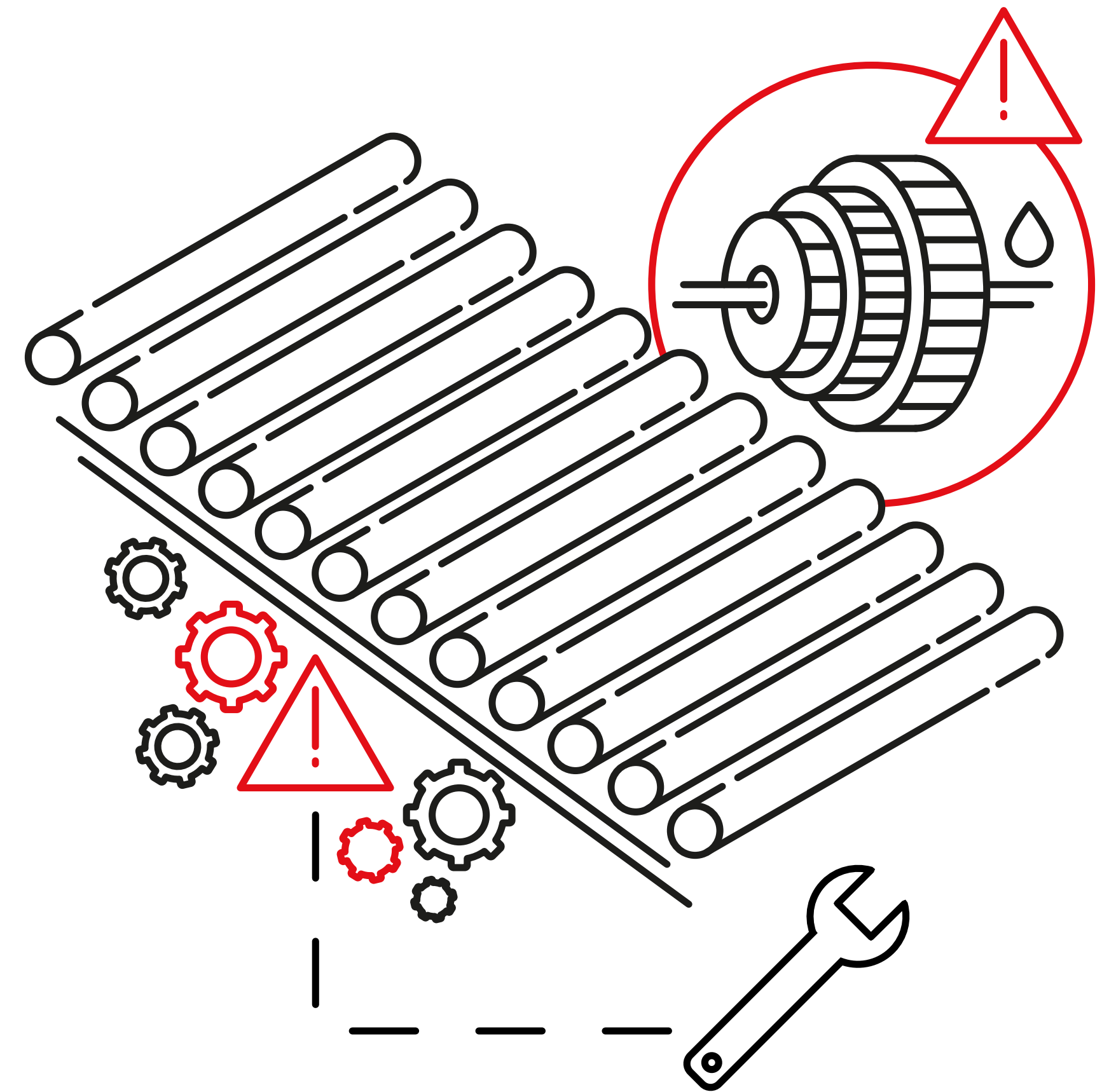

THE SOLUTION

By implementing RS Industria, the customer was able to gain real-time insight into the behaviour of each conveyor drive and get to the bottom of the high-wear issues.

Once the customer's stringent security standards for linking internal data networks to the internet were met, the variable speed conveyor drives were connected to the cloud-based RS Industria system.

The resulting data showed the key operating variables of current, voltage, and power consumption data in real-time, while automatically calculating torque and other related variables. This included integration of the process control system within the parcel sorter and carousel so the team could gain a better understanding of how the different conveyors were being used and when.



THE OUTCOME

By giving the customer greater insight into how the asset was operating, the resulting data could be used to help create a better-informed maintenance strategy.

RS Industria also shed light on the underlying issues at the root of high-wear and contamination challenges. Unbeknown to the customer's current operations team, the speed of the conveyors had been previously changed to match the increased volume of parcels, therefore exceeding the machine's original design capacity.

These actions had inadvertently caused shock load and put stress on the machine's components by over-speeding the motor. Meanwhile, gearbox oil samples also revealed contamination due to gear teeth wear.

As a result of the insight, the customer was immediately able to reduce wear by reprogramming the drive acceleration profile and replace the gearbox oil with a better-matched specification to prevent degradation.



NEXT STEPS

The insight gathered provided the customer with a viable and cost-effective solution to maintain the higher throughput volume of parcels, without resorting to an expensive machine redesign and rebuild.

The steady stream of monitoring data has also enabled the customer to proactively refine their parcel sorter machine operating procedures to minimise wear, allowing the team to measure the gear wear rates via drive torque, optimise the drive power profiles, plan oil changes, and schedule gearbox overhauls.

By implementing RS Industria on an ongoing basis, the customer is using a more cost-effective 'monitor & manage' solution to continuously assess the condition of the key gearbox components. This data empowers the customer to replace parts when necessary and proactively manage stock requirements to reduce unnecessary downtime.



INDUSTRIA

[RS-INDUSTRIA.COM](https://rs-industria.com) | [+44 \(0\)333 2470235](tel:+443332470235) | RS-INDUSTRIASUPPORT@RS-COMPONENTS.COM